

SECTION 4 CHARTS AND DIAGRAMS

4.1 DEMODULATOR CIRCUIT BOARD

**<14> DEMODULATOR
LPB10060-001B**

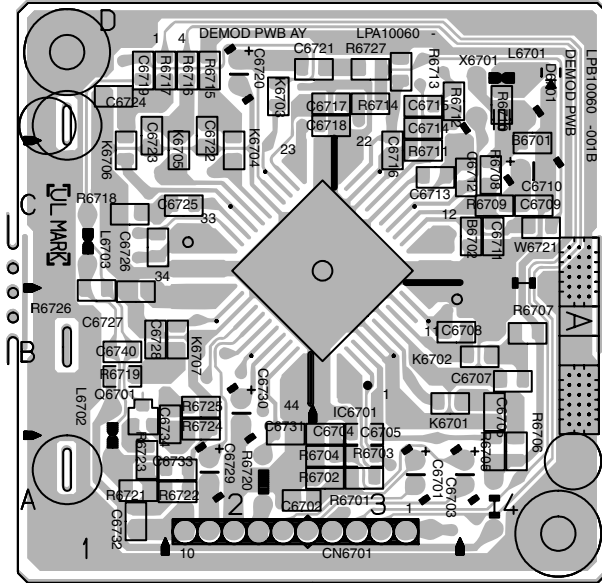

**COMPONENT PARTS LOCATION GUIDE
<DEMOMODULATOR>**

REF.NO.	LOCATION	REF.NO.	LOCATION	REF.NO.	LOCATION
CAPACITOR					
C6701	A D 3A	C6729	A D 2A	R6708	B C 4C
C6702	B C 2A	C6730	A D 2B	R6709	B C 4C
C6703	A D 4A	C6731	B C 2B	R6710	B C 4D
C6704	B C 3B	C6732	B C 1A	R6711	B C 3C
C6705	B C 3B	C6733	B C 2A	R6712	B C 3D
C6706	B C 4B	C6734	B C 2B	R6713	B C 3D
C6707	B C 4B	CONNECTOR			
C6708	B C 3B	CN6701	A D 3A	R6714	B C 3D
C6709	B C 4C	DIODE			
C6710	A D 4C	D6701	B C 4D	R6715	B C 2D
C6711	B C 4C	IC			
C6712	B C 4C	IC6701	B C 3C	R6716	B C 2D
C6713	B C 3C	COIL			
C6714	B C 3D	L6701	A D 4D	R6717	B C 2D
C6715	B C 3D	L6702	A D 1A	R6718	B C 1C
C6716	B C 3C	L6703	A D 1C	R6719	B C 1B
C6717	B C 3D	TRANSISTOR			
C6718	B C 3D	Q6701	B C 1B	R6720	A D 2A
C6719	B C 1D	RESISTOR			
C6720	A D 2D	OTHER			
C6721	B C 3D	R6701	B C 3A	K6701	B C 3B
C6722	B C 2D	R6702	B C 3A	K6702	B C 4B
C6723	B C 1D	R6703	B C 3A	K6703	B C 2D
C6724	B C 1D	R6704	B C 3A	K6704	B C 2C
C6725	B C 2C	R6705	B C 4A	K6705	B C 2C
C6726	B C 1C	R6706	B C 4A	K6706	B C 1C
C6727	B C 1B	R6707	B C 4B	K6707	B C 2B
C6728	B C 1B	X6701	A D 4D	X6701	A D 4D

4.2 DEMODULATOR SCHEMATIC DIAGRAM

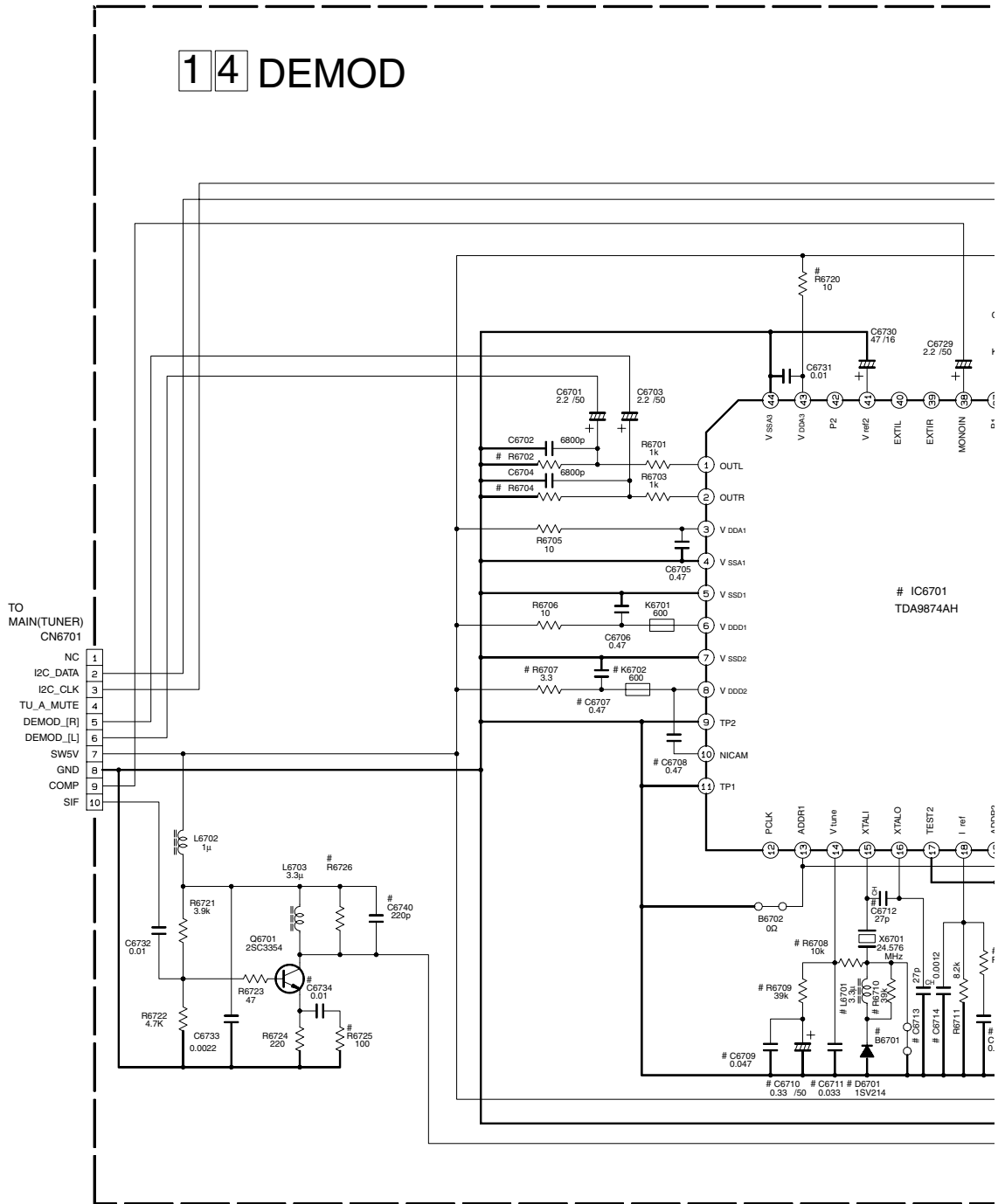

Note : The Parts Number, value and rated voltage etc. in the Schematic Diagram are for references only. When replacing the parts, refer to the Parts List.

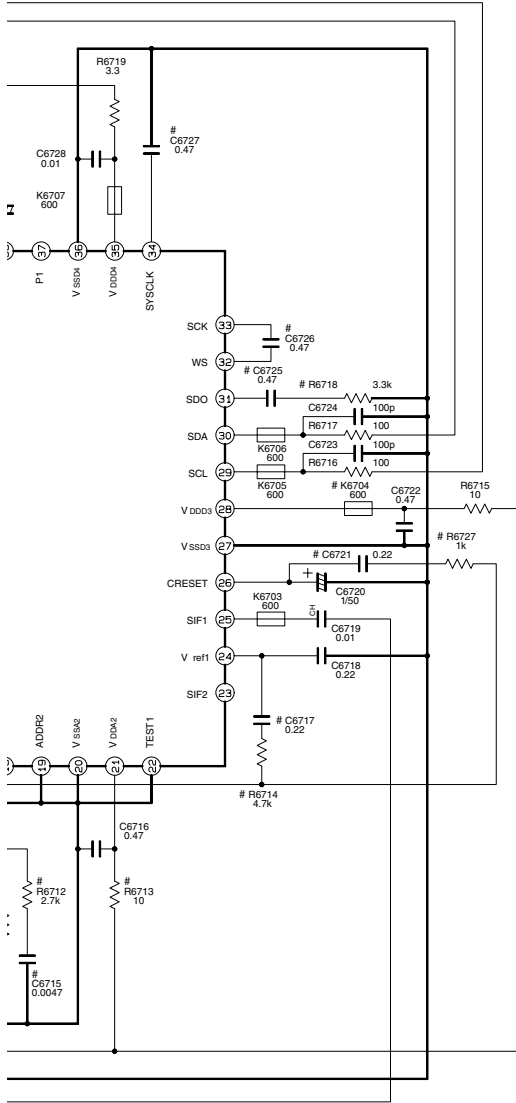

DIFFERENCE TABLE

	V12 EK/ARC	V12 EU/MS	V13/V14
IC6701	TDA9874H	←	TDA9874AH
R6707	10	←	NOT USED
R6708	10k	←	0Ω
R6709	39k	←	NOT USED
R6710	39k	←	NOT USED
R6713	10	←	NOT USED
R6720	10	←	NOT USED
R6725	100	NOT USED	100
R6726	1k	2.2k	1k
C6707	0.47	←	NOT USED
C6710	0.33/50	←	NOT USED
C6711	0.033	←	NOT USED
C6712	27p	←	NOT USED
C6713	27p	←	0Ω
C6714	0.0012	←	NOT USED
C6734	0.01	NOT USED	0.01
C6740	NOT USED	220p	NOT USED
L6701	3.3μ	←	NOT USED
D6701	1SV214	←	NOT USED
K6702	600	←	NOT USED
R6702,R6704, R6712,R6714, R6717,R6718, C6708,C6709, C6715,C6717, C6721,C6725, C6726,C6727, B6701	NOT USED	←	←